

## Features

- Suitable for Class I, II/Div. 2 for hazardous locations
- Certified for UL CSA
- Manifold combines the solenoid valve for purging and needle valve for pressurization in one housing
- Suitable for steel or plastic tubing
- Mounting hardware, pneumatic fittings and tubing included

## Application

The 5500-MAN-CDUL-\* combines a solenoid valve for purging and a needle valve for pressurization in one manifold design. When the valve is energized, the solenoid valve opens and allows for a high flow rate of protective gas into the enclosure. When the valve is de-energized, the flow through the internal needle valve is adjustable by using the included Hex key. The solenoid valve is used for purging, leakage compensation, and temperature control by signals from user defined points on the 5500 control unit.

Mounting hardware includes 3/8" tube compression fittings mounted on the manifold for input and output flow, 3/8" tube compression bulkhead fitting for getting flow into the enclosure and certified sealing washers with bolts to mount the manifold to the enclosure. Also included is 1 meter of 3/8" poly tubing with 3/8" poly tube stiffener inserts which allows the connection of plastic tubing to compression fittings without collapsing the tubing.

For NEC, ATEX and IECEx applications see the model number key for proper manifold selection.

The 5500 valve system works with the 5500 control unit and EPV-5500 vents. The 5500 system has UL certification for Class/Division installation.

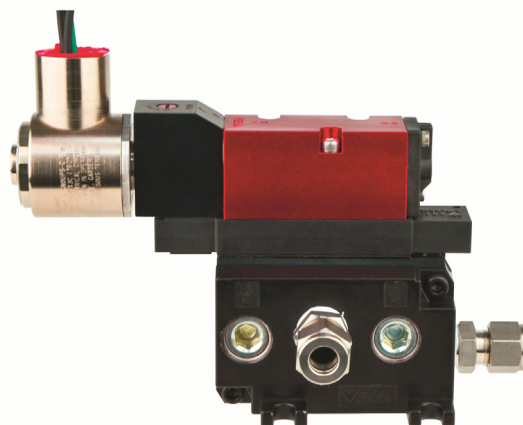

**BEBCO EPS®**

## Dimensions

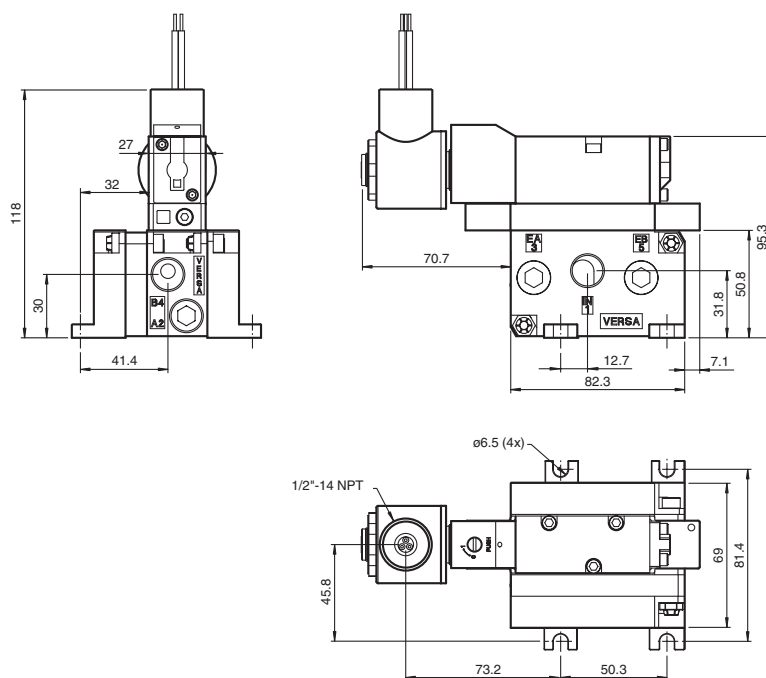

<b>General specifications</b>	
Operating mode	automatic purging
Series	5500
Hazardous environment	gas or dust
<b>Supply</b>	
Rated power	24 V DC: 5.6 W Voltage tolerance: +/- 10 %
<b>Electrical specifications</b>	
Fuse rating	500 mA (fuse rating on 5500 control unit)
<b>Pneumatic parameters</b>	
Protective gas supply	instrument grade air or inert gas
Pressure requirement	1.4 bar (20 psi) to 8.2 bar (120 psi)
Purge flow rate	solenoid valves : Cv (flow coefficient) = 1.4 needle valve : Cv (flow coefficient) = 0.24
<b>Ambient conditions</b>	
Ambient temperature	-20 ... 50 °C (-4 ... 122 °F)
<b>Mechanical specifications</b>	
Connection type	Pneumatic Input port: 3/8 inch Tube compression fitting Output port: 3/8" Tube compression fitting  Electrical connection 1/2" NPTF thread connection w/ 24" (0.61m) flying leads
Degree of protection	type 7 & 9
Material	<b>Housing:</b> anodized aluminum <b>3/8" compression fittings:</b> 316 stainless steel <b>Pressure ports:</b> 3/8" NPTF <b>Bulkhead fitting:</b> 316 stainless steel <b>Mounting bolts:</b> 1/4 - 20, 316 stainless steel <b>Sealing washers:</b> UL recognized type 4X
Mass	1250 g (2.8 lb)
Dimensions	see dimensions
<b>Data for application in connection with hazardous areas</b>	
Certificate	
Temperature class	T3C
<b>International approvals</b>	
UL approval	
cULus	Class I Division 2, Group A-D Class II Division 2, Group F+G
CSA approval	Class I Division 2, Group A-D Class II Division 2, Group F+G

**Type code/model number**

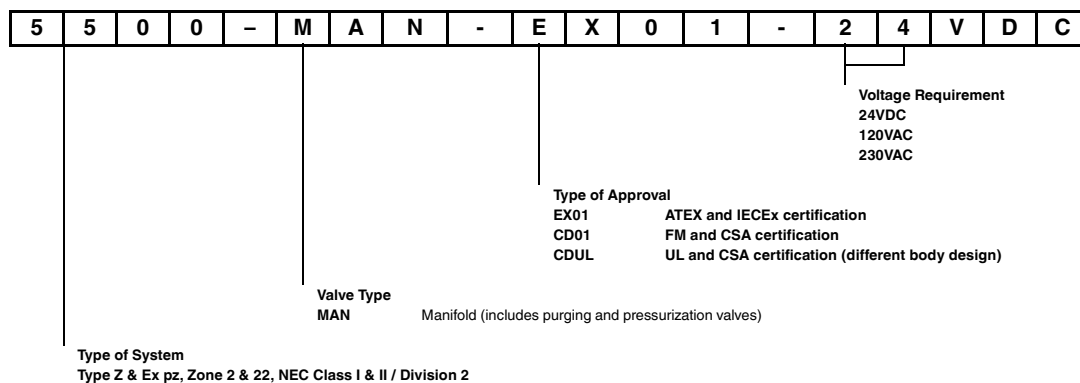

Release date 2019-07-24 23:13 Date of issue 2019-07-24 70110799\_eng.xml